



شركة نما التكاملية
NAMAA INTEGRATED CO. LTD.

Profile 2026

تجهيز وتصنيع معدات المطاعم والفنادق والمطابخ المركزية وجميع أعمال الإستانلس ستيل والحديد والألمنيوم والزجاج
Processing and manufacturing of restaurant equipment, hotels, central kitchens and all stainless steel, iron, aluminum and glass works

شركة نما التكاملية
NAMAA INTEGRATED CO. LTD.

Processing and
manufacturing of
restaurant
equipment,
hotels, central
kitchens and all
stainless steel,
iron, aluminum
and glass works

تجهيز وتصنيع معدات
المطاعم والفنادق
والمطابخ المركزية
وجميع أعمال الإستانلس
ستيل والحديد والألمنيوم
والزجاج

ص.ب ٤٧٨٣ الرمز البريدي ٣٢٤٢٥ - الدمام - حي الخليج - شارع الملك سعود، قبل شركة الكهرباء - المملكة العربية السعودية - جوال: ٠٥٩٠٤٩٨٨٨١ - ٠٥٨٠٠٨٨٧٦٧
PO Box 483 P.Code 32425 - Dammam - Al Khaleej District - King Saud Street, before (SEC) - KSA. - Mob.: 0580088767 - 0590498881
س.ت. ٧٠٥٨٢٤٥٨٤ - الرقم الضريبي: ٣١٤٢٦٠٤٠٠٠٠٣ | ٣١٤٢٦٠٤٠٠٠٠٣
www.namaa-integratedco.com - Info@namaa-integratedco.com

ص.ب ٤٧٨٣ الرمز البريدي ٣٢٤٢٥ - الدمام - حي الخليج - شارع الملك سعود، قبل شركة الكهرباء - المملكة العربية السعودية - جوال: ٠٥٩٠٤٩٨٨٨١ - ٠٥٨٠٠٨٨٧٦٧
PO Box 483 P.Code 32425 - Dammam - Al Khaleej District - King Saud Street, before (SEC) - KSA. - Mob.: 0580088767 - 0590498881
س.ت. ٧٠٥٨٢٤٥٨٤ - الرقم الضريبي: ٣١٤٢٦٠٤٠٠٠٠٣ | ٣١٤٢٦٠٤٠٠٠٠٣
www.namaa-integratedco.com - Info@namaa-integratedco.com

Cabintes

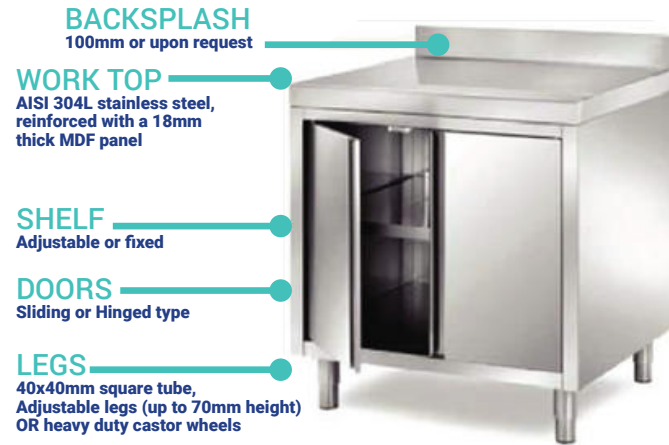

Ideal for any area in your commercial or Industrial kitchen, a stainless steel cabinet is a great way for your staff to prepare a variety of your most popular dishes. These worktop cabinets can be used to support dozens of different food preparation appliances, storage containers, and more so that your staff can work diligently and efficiently throughout the day. And thanks to their sealed bases, each enclosed base cabinet can store nearly any product that you have. These are built in a wide range of sizes so you can pick a product that best fits the space you have in your kitchen. In addition, many of these cabinets come with doors to help keep stored contents sanitary throughout the day. You can even find with backsplashes to protect your walls as your staff works.



1 Door Base Cabinet Without top



2 Door Base Cabinet Without top



2 Door Base Cabinet Sliding, Without top



1 Door Base Cabinet With top



1 Door Base Cabinet With backsplash



2 Door Base Cabinet With top



2 Door Base Cabinet Sliding, With top



2 Door Base Cabinet With backsplash



2 Door Base Cabinet Siding. With backsplash



2 Door Base Cabinet Sliding. With packsplash



Corner Base Cabinet With backsplash



2 Door Base Cabinet With high backsplash



Wall Cabinet Hinged door



Wall Cabinet Slicing door



Wall Cabinet 3 doors Hinged type



Wall Cabinet Corner type



1 Door Base Cabinet With pull-out drawer



2 Door Base Cabinet With 2 under drawers



Base Cabinet With oull-out drawer and 3 side drawers



1 Door Base Cabinet With 3 side drawers



2 Door Base Cabinet With 3 sice drawers



2 Door Base Cabinet Sliding, With 3 side drawers



Base Cabinet With 3 side drawers and mobie trolley



1 Door Base Cabinet With 3 side drawers and open shelves



2 Door Base Cabinet. With 3 drawers on both side



Base Cabinet With 6 drawers



1 Door Base Cabinet With 3 side drawers and mooile trolley



Base Cabinet 3 drawers poth side and open snelves

Sinks

TYPE OF STEEL

Standard 304 or 3G for corrosion resistance

GAUGE OF STEEL

Select superior 18 gauge or stronger contrecal grade 16 Gauge

RIM

Raised with dro-ledge for drop in or flat for undermoun



FAUCET HOLES

Add move or renlove holes at no additional charges

BOWL DEPTH

Con be deeper or smalk bowl. rom 20 cm up to 50cm

DRAIN LOCATION

Drain car be in the center or offset to the back or the side

CLEAN DISHES, WASH HANDS, OR COMPLETE CLEANING TASKS BY USING OUR SINK.....

Ensure Dat your restaurant hea tal warehouse, or other type of establishment slaya sanitary by selling a commercial Industrial sink. Our selection ncludes compertinent suka, underbar siks, hand sriks, janitonel s riks, and more, As a result, you can ine opcions for al ol your als wasting, hand washing, or filling nop auckets tasks Additionally, each of these products 's designed specifically. to meet the needs of your business, and keep your operation san sary and safe



Handwash Sink Wall Type, with high splashguard



Knee Operated Handwash Sink



Knee Operated Handwash Sink With soap dispenser



Freestanding Foot Operated Handwash Sink



Handwash Sink Foot Operated, with soap dispenser



Foot Operated Handwash Sink Freestanding



Foot Operated Handwash Sink Freestanding



Freestanding Handwash Sink With support legs



Pot Wash Sink With undershelf



Single Bowl Sink With undershelf



Single Bowl Sink With hole and space under for bin



Fish Wash Sink



Double Bowl Sink Table Centered, with undershelf



Double Bowl Sink Table With undershelf



With drainboard and undershelf



Double Bowl Sink Table With drainboard and undershelf



Double Bowl Sink Cabinet With hinged/sliding doors



Fish Wash Sink Cabinet With hinged/sliding doors



Double Bowl Sink Cabinet With drainboard, hinged/sliding doors



Double Bowl Sink Cabinet With 3 drawers, hinged/sliding doors

Shelving units



Transform your crowded freezer, warehouse, dish room, or other storage facility into a well-organized area with heavy-duty shelving units. These also help you to keep important ingredients and supplies stored safely.

Additionally, we offer a wide variety of customization options to accommodate spaces of all shapes and sizes.

**Keep Your Kitchen
and Storage Area
Organized**

Wall Shelf



Storage units



Browse our assortment of storage/ shelving units for a convenient and affordable way to expand your organization setup. We carry rust-resistant units for walk-in refrigeration, shelving specially designed for retail and warehouse storage options.





Cold Bain Marie Cabinet
With open space under



Cold Bain Marie Cabinet
With 2 hinged doors



Hot Bain Marie Cabinet
With 2 hinged doors



Hot Bain Marie Cabinet
With open space under



Bain Marie Cabinet
Open With overhead shelves



Bain Marie Cabinet
2 Door and overhead shelves



Bain Marie Cabinet
Sliding and overhead shelves



Bain Marie Cabinet
With overhead shelves



Cold Bain Marie Cabinet
Open, With overhead shelves



Cold Bain Marie Cabinet
Sliding, With overhead shelves



Bain Marie Cabinet
2 Doors and overhead shelves



Hot Overhead Shelves



Need to cook food and keep it at optimum serving temperature?

It hold food at the proper serving temperature from steam tables to soup wells, drawer warmers to heat lamps, find the proper food holding equipment you need for your catering, buffet, or other foodservice business.

Whether you need food warming equipment for hot dishes or a refrigerated unit for storing perishable products, you'll find the best piece of equipment to suit your food storage needs



Cocktail Station



Cocktail and Blender Station



Cutlery dispenser



Cutlery trolley



Hoods

Hood systems are essential to keeping your kitchen free of hazardous grease buildup.

Every commercial and industrial kitchen, regardless of size or location, is required to safely vent heat, smoke, and grease laden air from the kitchen to prevent fires and keep employees comfortable. Kitchen hoods are typically made of stainless steel in order to hold up well for long use without easily getting rust or dents. Our hoods collect the grease particles produced by your kitchen equipment and trap it in baffle-type filters. The filters can then be removed and cleaned to maintain sanitary conditions in your kitchen.

There are units that can be placed flush against the wall. Island hoods are available for installation on ceilings for equipment placed in the middle of the kitchen. Our collection of hood systems includes both venting hoods for smoke and grease and venting hoods for heat and steam.

These hood system units are guaranteed to meet building codes and requirements.

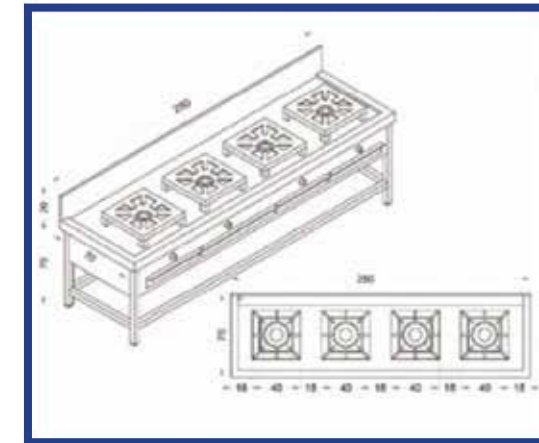

2-Burner Table



3-Burner Table



4-Burner Table



2-Burner Table with high splashguard



3-Burner Table with high splashguard



4-Burner Table with high splashguard



2-Burner Chinese Cooking Range

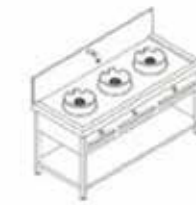

3-Burner Chinese Cooking Range



4-Burner Chinese Cooking Range

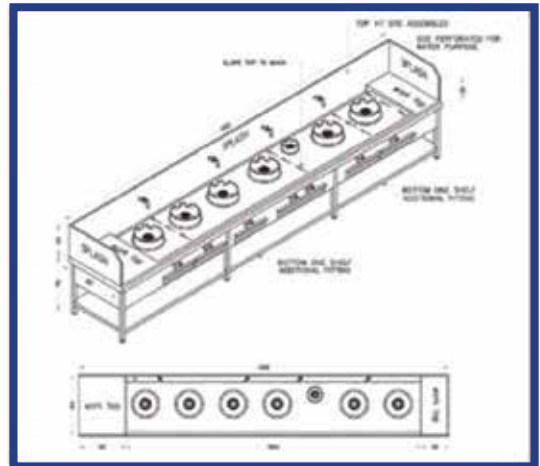

Kunafa Machine



Double Saj Burner

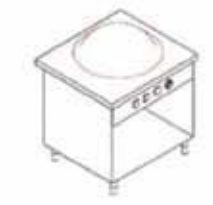

Single Saj Burner



Double Skin Hood
Type: Wall/Island



Single Skin Hood
Type: Wall/Island



Island Exhaust Hood
Skin: Single/Double



Canopy Hood



Tandoor Unit



Mobile Tandoor



Falafel Fryer



Smooth Griddle



Chapatti Griddle



Shawarma Machine - Double With Hood + Chiller + GN Container



Shawarma Machine - Double With Chiller + GN Container + Drawers

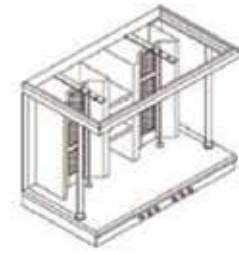

Shawarma Machine - Double Table Top



Shawarma Machine - Single With bottom cabinet + drawer

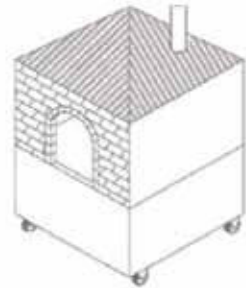

Gas Pizza/Fatayer Oven

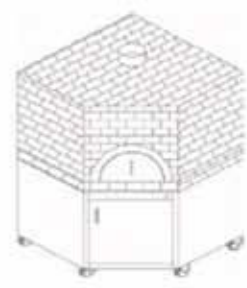

Gas Pizza/Fatayer Oven



Muti-purpose Gas Oven

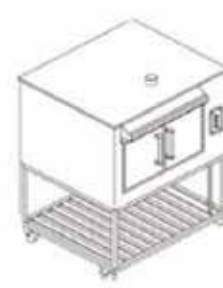

Gas Oven

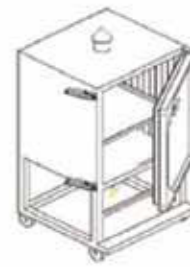

Mobile Gas Oven



Holding Cabinet

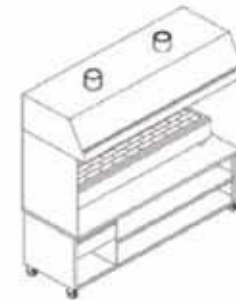

Barbeque Grill With bottom table + hood



Barbeque Grill With hood + doors and bottom storage

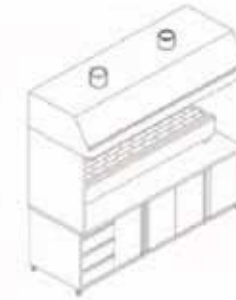

Barbeque Grill With bottom cabinet + hood



Barbeque Grill Table Top



Barbeque Grill With enclosed Panel and Chiller



Barbeque Grill With Hood and Chiller

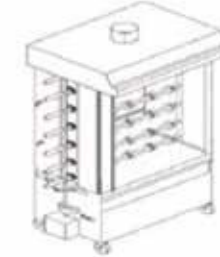

Chicken Grill 7 Skewers



Chicken Grill 5 Skewers

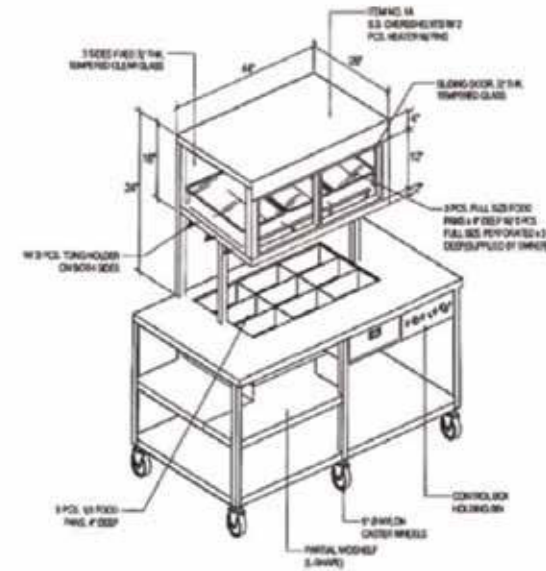

Freestanding Charcoal Grill



Charcoal Grill With bottom Cabinet



It's important to choose high-quality equipment that will stand up to the high demands of a busy kitchen environment. You'll find that our heavy duty cooking equipment features stainless steel construction for corrosion resistance and long service life.

We ensure that you'll find our selection of reliable, durable and innovative kitchen equipment that required something that fits your space and capacity needs, all at the lowest prices. Our products designed to support small-scale food service business to high-volume operations. We have a broad range of Arabic/Fatayer Oven, Shawarma Machine, BBQ Gril, which come in all shapes, sizes, and styles

Cooking Equipment

The choice of cooking that makes the difference



SOLIDITY

The use of top-quality extra-thick steel, with the attention to every detail throughout the production process is just some of the features that make Baron Kitchens so unique.

RELIABILITY

The choice of materials and the quality of construction give Baron Kitchens their extreme reliability and durability, making them the perfect partner for every professional chef.

FLEXIBILITY

The wide range of models means you can choose the solution for your own personal needs. From classic gas and electric Ranges to computerized Fryers and Bratt Pans, through to products for special purposes.



Gas Ranges
Gas burners 2.4. C and 8
Fully moulked top
High power cast iron burners
Gas/Electric ovens
able top and I reestanding
Length: 400mm, 800mm, 1200mm
width: 600mm, 700mm, 900mm



Electric Ranges
Hob 2 anc 4 phtes
Fully mou dec hoa
Water tight cas: inom radiant plates
Electric sens
lable cop and I reestanding
Length: 400mm and 800mm;
width: 700mm ard 900mm



Fryers
Single and Double Baske
Fully trouled top
Automatic temp. adjustment the
nostat up to 190°C.
I ire proof safety thermostat (220°C)
Length: 400mm and 800mm:
Width: 700mm and 300mm



Griddles
Soft iron or polished chrome griddle.
Lowered gr Idle too & tilted to drain
fat: Wice drawer for fat collection
Tena, adjustmen: 200°C to 40000
able top and I reestanding
Length: 400mm and 300mm:
Width: 700mm and 900mm



Grills
Adjustable steel coxing grille
Kemovable drawer for fat collection
Inert volcanic lava with radiant
features compatible with food
Length: 400mm and 800mm.
Width: 00mini anc 900nim



Induction Ranges
Hob-2 anc 4 plates
Watertight shatterproof glass-ce-ra-
mik top: Presence detector device
anc overhear device.
Length: 400mm and 800mm;
Width: 700mm ard 900mm



Potato Warmer
Greater resistance with infrared
radiat on.
I over resistance underneath tub.
Ad ustible temp.: 330 50°C
Length: 400mm
Width: 700mm and 400mm



Solid Tops
Cast iron arushed griddle with
removable central di sc
High power cast hon burners
Heating zones: 5000 max temp.
Length: 400mm and 300mm
Width: 700rm and 900mmmm



Pasta Cooker
Single and Double Tank
Up to 26 S/S 310 coking tank
Multi-position power regulator
Stainless-steel interior and exterior
Length: 400mm and 200mm.
Width: Comini anc 900nini



Bratt/Tilting Pans
Manual water fil.
Self-balanced lid with double sreel wall
with Safety device
Adjustable temp. 100 to 280°C.
_ength: 800mm
woch: 100mm anc 900mm



Boiling Pans
Manual water fil.
-worer drained with valve
Safety thermostat heating unt I restore
of sufficient water level
Length: 800mm
Width: 700mm and 900mm



Wok
S/steel Outer casing and teelt
Right 'ear drain with
With crease collection diaw
Length: 600mm and 1000mm
Width: 733mm and 900mm



Refrigeration Equipment

The line of equipment that best meet your requirements

Enhance your fresh or prepackaged products in a setting with clean and modern design. With the refrigerated equipment you ensure the functionality of an optimal conservation at adequate temperatures for each food without sacrificing aesthetics.

All the chill you need to express fully the potentiality of your kitchen or restaurant. You can ensure wholesomeness and respect for the raw material thanks to controlled temperature preservation processes, from fast blast chilling to long-term refrigeration.



Upright Chiller/Freezer
700 Liters Capacity
Temp: C/-10°C-18/-22°C R404A/R507
Gas Refrigerant
Stainless-steel interior and exterior
Size: 710 x 800 x 2030/2100mm



Upright Chiller/Freezer
1400 Liters Capacity
Temp: 0/+10°C-16-22°C
R404A/R507 Gas Refrigerant
Stainless-steel interior and exterior
Size: 1420 x 800 x 2030/2500mm



Upright Chiller/Freezer
700 Liters Capacity
Temp: 0/-10°C-18/-22°C
R404A/R507 Gas Refrigerant
Stainless-steel interior and exterior
Size: 1420 x 800 x 2030/2100mm



Upright Chiller/Freezer
1400 Liters Capacity
Temp: 0/-10°C-18/-22°C
R404A/R507 Gas Refrigerant
Stainless-steel interior and exterior
Size: 1420 x 800 x 2030/2100mm



Counter Chiller/Freezer
310 Liters Capacity
Temp: 0/+10°C-18-22°C
R404A Gas Refrigerant
Stainless-steel interior and exterior
Size: 1420 X 700 X 850/920 mm



Counter Chiller/Freezer
460 Liters Capacity
Temp: 0/+10°C-18/-22°C
R404A Gas Refrigerant
Stainless-steel interior and exterior
Size: 1870 x 700 x 850/920 mm



Counter Chiller/Freezer
620 Liters Capacity
Temp: 0/+10°C-18/-22°C
R404A Gas Refrigerant
Stainless-steel interior and exterior
Size: 2320 x 800 x 2030/2100mm



Blast Chiller/Freezer
Capacity: 5, 10, 15 & 20 Trays
GN V (600x400mm)
R404A/R507 Gas Refrigerant
S/steel interior and exterior
Size: 750(L) * 740(W) * mm



Salad Counter
220 Liters Capacity
Temp: +4/+10 °C
R404A/R507 Gas Refrigerant
Stainless-steel interior and exterior
Size: 930 x 730 x 1000 mm



Salad Counter
220 Liters Capacity
Temp: +4/+10 °C
R404A/R507 Gas Refrigerant
Stainless-steel interior and exterior
Size: 1410 x 700 x 11070 mm



Salad Counter
220 Liters Capacity
Temp: -4/+10 °C
R404A/R507 Gas Refrigerant
Stainless-steel interior and exterior
Size: 2040 x 750 x 1030/1100 mm



Pizza Counter
220 Liters Capacity
Temp: +4/-10 °C
R404A/R507 Gas Refrigerant
S/steel interior and exterior
Size: 1410 x 700 x 11070 mm

COLD ROOM CHILLER/FREEZER



Operating Temp.	Freezer Room: -18 to -20°C Chiller Room: 0 to +4°C
Insulation	Panels with press injected rigid CFC free polyurethane foam. The foam has a fine cell structure, which offers excellent aging properties and good dimensional stability at very low temperature.
Panel Thickness	100mm
Density	40-42kg/m³
Cladding	Polyester pre painted 0.5mm thick hot dipped galvanized steel sheets with nylon protective film (ribbed)
Floor	100mm Insulated panels with wooden spacers, covered with 12mm marine plywood and wearing surface finish with 2mm Aluminum Checkered Plate
Doors	1 No. Manual Hinged Doors. Doors will have same finishing and thickness that of the wall and ceiling complete with accessories, rubber gaskets, door heaters, emergency reflection light, internal safety release handle etc (make-KASON, USA or equivalent)
Lighting	Vapor proof corrosion resistant low florescent double tube lights IP 65 will be provided for sufficient lighting in the cold room.
Safety Pressure Valve	Compensation valve shall be assembled in the cold room to balance the low pressure caused by air cooling and the external pressure of the door.
Accessories	All panel accessories supplied and installed shall be L shaped galvanized steel sheets for ceiling the external comers and aluminum angles for the internal corners duly fixed with rivets and special silicon.
Construction	Panels are joined together by means of tongue and groove and locked together by camlock (Kasson, USA or equivalent) spaced every 1000mm cc on each side of the panels to ensure air tight joints.

Food Preparation Equipment

Designed to provide exceptional quality results



Slicing, dicing, tenderizing, mixing, and other preparation tasks can be some of the most time-consuming duties in the kitchen. Don't waste time preparing all of your raw ingredients, vegetables or meat by doing it by hand, almost all professional kitchens and catering businesses can benefit with the addition of dedicated food preparation machines.

Simplifying the food preparation process enables your kitchen staff to focus on the art of cooking, enhancing food output and increasing the happiness of your diners.

Not only that but the quality of your food will improve due to the increased consistency of your pre-prepared raw ingredients; whilst food prep and food processing machines enabling your kitchen staff to take on other more intensive tasks, in turn, saving you money.



Food Processor Cutter and Vegetable Slicer



Vegetable Preparation Machine



Vegetable Preparation Machine Workstation



Vegetable Preparation Machine



Cutter Mixer - Table Top



Vertical Cutter Mixer



Vegetable Cutter



Blixer



Meat Mincer, 12-22mm



Meat Mincer, 42mm



Bone Saw Machine - Anodized



Bone Saw Machine Inox



Potato Peeler



Cheese Grater



Power Mixer



Hamburger Press Machine



Manual Sausage Stuffer

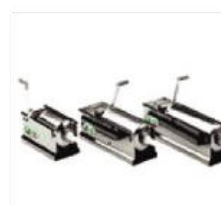

Sausage Filler



Hotdog Machine

Beverage Equipment

Ensure to have everything for your perfect drinks



Espresso Coffee Machine
Lever Type-2 Group



Espresso Coffee Machine
Push Button Type - 1 Group



Espresso Coffee Machine
Push Button - Semi Automatic



Espresso Coffee Machine
Push Button Type - 3 Group



Automatic Coffee Machine
With Grinder



Office Pulser Espresso
Machine - 1 up to 3 group



Coffee Grinder
Semi-Automatic



Coffee Grinder
120 kg. capacity



Turkish Coffee Maker



Coffee Filter Machine



Milk Mixer



Water Boiler

We have the perfect hot drink dispenser for your commercial kitchen or cafeteria, with cutting-edge cappuccino dispensers, coffee and tea brewers, coffee warmers, and more.

If you need professional coffee shop equipment - such as a commercial cappuccino machine or a large-volume espresso maker that makes barista-style coffee drinks fast - you'll find an option here that matches your needs and budget. These systems are essential for ensuring that you always have delicious, hot coffee on hand throughout the day.



Brushless Blender



Bar Blender



Juice Extractor



Citrus Juicer



Automatic Centrifugal
Juicer



Juice Dispenser



Cold Drinks Machine



Slush / Sherbet/Cold
Creams Machine



Dessert/Ice Cream
Machine



Freestanding Ice Cream
Machine



Ice Crusher



Ice Cube Maker with Bin
20 kg up to 155 kg



Ice Flaker with Bin
90 < up to 50 <3



Ice Cube Maker with Bin
140 kg up to 750 kg



Ice Flaker with Bin
5.0 kg up to 1000 kg



No food service business's complete without a cold beverage dispenser. We'll put up a quality beverage in seconds with soda dispensers, coffee dispensers and smoothie dispensers that keep drinks cold and dispense the perfect amount, for every cup.

We have everything from affordable, easy-to-clean drink servers to deluxe cold drink dispensers that chill and serve several different flavors at the same time.

With our commercial-grade blenders and juice extractors, you'll be able to create handcrafted smoothies and juices for your restaurant, brunch buffet or catering operation.

Dishwashing Equipment

Your perfect companion in cleaning dishes



Providing your staff with a stable supply of clean and sanitary dinnerware or glassware is important in the foodservice industry, and our selection of dishwashing equipment is the best option for this job. We carry a large selection of commercial dishwashers that are essential for any sanitary kitchen. These are also help you save time, because you won't need to wash each individual product by hand.



Our selection of commercial dishwashing equipment includes washers that are specially shaped to wash plates, glasses, pots, and pans. You can also find single or double rack models, undercounter styles, and conveyor units.



شركة نماء التكاملية

NAMAА INTEGRATED CO. LTD.

تجهيز وتصنيع معدات المطاعم والفنادق والمطابخ المركزية
وجميع أعمال الإستانلس ستيل والحديد والألمنيوم والزجاج
Processing and manufacturing of restaurant equipment, hotels, central
kitchens and all stainless steel, iron, aluminum and glass works

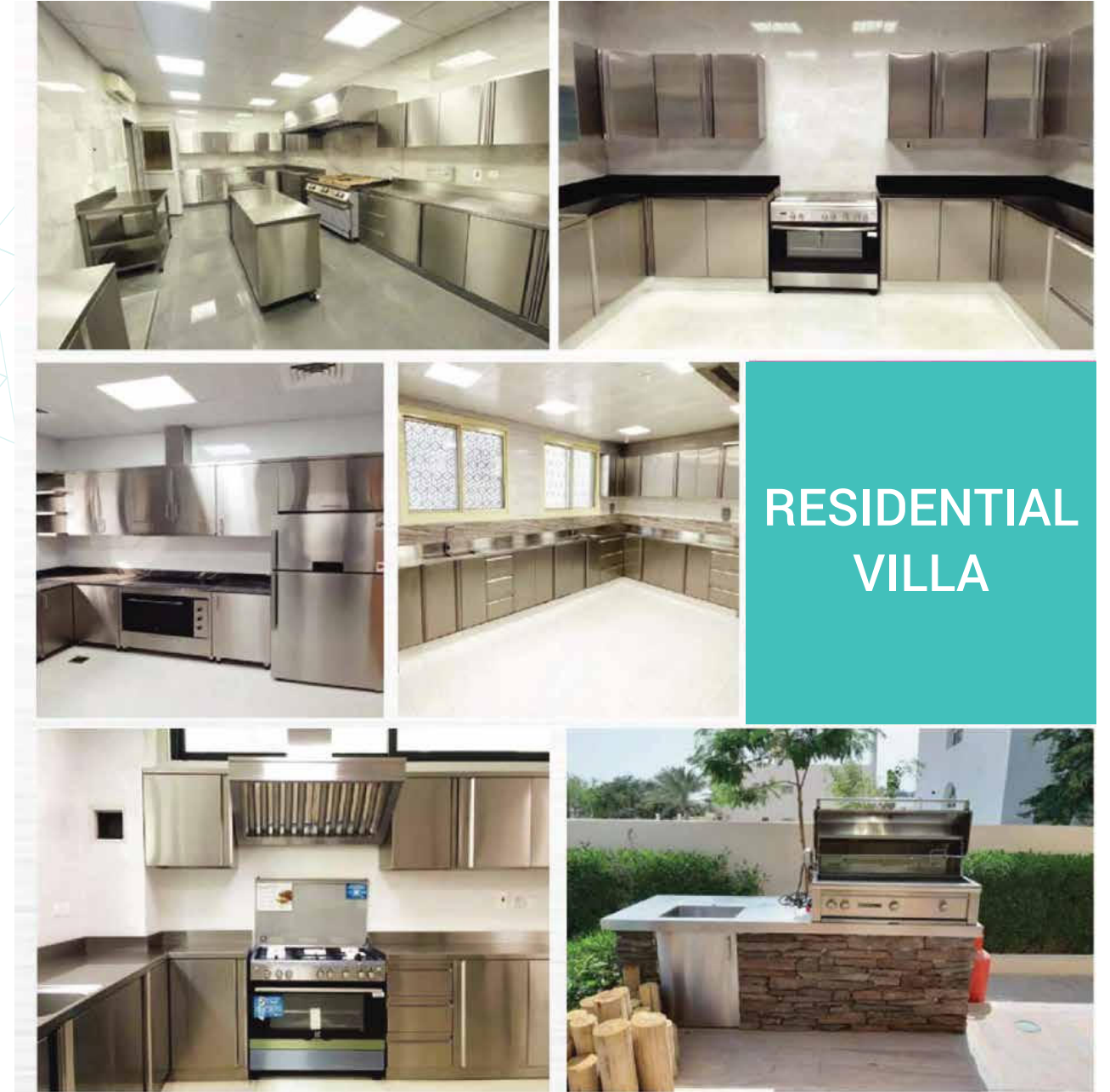

RESIDENTIAL
VILLA



HOTEL AND RESTAURANTS



CATERING AND PANTRY





LABOR
ACCOMMODATION
AND CENTRAL
KITCHEN



SUPERMARKETS
AND
BAKERIES



نحن متخصصون في تنفيذ مشاريع الغاز باعلي درجة كفاءة وحسب المعايير الدقيقة

We specialize in implementing gas projects with the highest degree of efficiency and according to precise standards.



وأیضا موردون وبأسعار تنافسية لجميع أنواع وأحجام خزانات الغاز حيث أننا وكلاء لعدة شركات عالمية متخصصة في معدات الغاز المسال والغازات الصناعية

We are also suppliers with competitive prices for all types and sizes of gas tanks, as we are agents for several international companies Specializing in Liquefied gas equipment and industrial gases.



Many projects have been completed in the Kingdom of Saudi Arabia Factories, hotels, residential and commercial complexes



نهدف إلى أن نكون الرواد في توفير حلول الغاز الآمنة والموثوقة والمستدامة في المملكة العربية السعودية، مع التركيز على رضا العملاء والابتكار.

We aim to be the pioneers in providing Safe, reliable and sustainable gas solutions In the Kingdom of Saudi Arabia, Focusing on customer satisfaction and innovation

We are committed to providing extension services High quality according to the highest LPG gas Standards, using the latest technologies and practices to ensure the safety of our customers And their comfort

نحن ملتزمون بتوفير خدمات تمديد الغاز LPG عالية الجودة وفقا لأعلى المعايير باستخدام أحدث التقنيات والممارسات لضمان سلامة عملائنا وراحتهم.



- **السلامة:** نضع سلامة عملائنا وموظفينا في صميم عملنا.
- **الجودة:** نقدم خدمات عالية الجودة تلي توقعات عملائنا وتتجاوزها.
- **الموثوقية:** نلتزم بالوفاء بوعدونا وتقديم خدمات موثوقة في الوقت المحدد.
- **الابتكار:** نسعى باستمرار إلى تطوير خدماتنا وتبني أحدث التقنيات.
- **الاستدامة:** نساهم في الحفاظ على البيئة من خلال تبني ممارسات مستدامة.

- **Safety:** We set the safety of our customers and employees of the heart of our work.
- **Quality:** We provide high-quality services that meet and exceed our customers expectations.
- **Reliability:** We are committed to keeping our promises and providing reliable services on time.
- **Innovation:** We constantly strive to develop our services and adopt the latest technologies.
- **Sustainability:** We contribute to preserving the environment by adopting sustainable practices



توفير خزانات الغاز المسال:

توريد وتركيب خزانات الغاز المسال بمختلف أحجامها وأنواعها للمقطاع الخاص والحكومي والأفراد.

تمديدات الغاز LPG للمنازل والمباني التجارية:

نقوم بتصميم وتركيب وصيانة شبكات الغاز LPG بأعلى معايير السلامة والجودة.

حلول الغاز الصناعية:

نقدم حلول غاز مخصصة لتلبية احتياجات مختلف الصناعات.

عقود الصيانة:

نوفر عقود صيانة دورية لضمان سلامة وكفاءة أنظمة الغاز.

الخبرات:

لدينا فريق على قدر عالي من الاحترافية في الكشف عن تسريبات الغاز ومعالجتها بسرعة وجودة عالية

الاستشارات الفنية:

نقدم استشارات فنية للعملاء لمساعدتهم في اختيار الحلول الأمثل لاحتياجاتهم.

-Providing liquefied gas tanks:

Supply and installation of liquefied gas tanks of various sizes and types

-LPG gas installations for homes and commercial buildings:

We design, install and maintain LPG gas networks with the highest standards of safety and quality

-Industrial Gas Solutions:

We provide customized gas solutions to meet the needs of various industries.

-Maintenance contracts:

We provide regular maintenance contracts to ensure the safety and efficiency of gas systems.

-Experiences:

We have a highly professional team in detecting gas leaks Processed quickly and with high quality

-Technical consulting:

We provide technical consultations to clients to help them choose the optimal solutions for their needs





شهادة السجل التجاري

شركة نماء التكاملية

الرقم الوطني الموحد: 7051824584

تاريخ الإصدار: 28/09/2025

نوع الكيان: شركة ذات مسؤولية محدودة

صفات الشركة: (شخص واحد)

حالة السجل: نشط

البيانات الأساسية للسجل التجاري



7051824584

شهادة تسجيل في ضريبة القيمة المضافة
VAT Registration Certificate

تشهد هيئة الزكاة والضريبة والجمارك بأن المصنف أدناه مسجل في ضريبة القيمة المضافة بتاريخ ٢٠٢٥-٠٩-٢٨ م
The Zakat, Tax and Customs Authority certifies that taxpayer below is VAT registered on 28/09/2025 AD

اسم المصنف	شركة نماء التكاملية
رقم التسجيل الضريبي	314260400200003
تاريخ نفاذ التسجيل	2025/10/01
عنوان المصنف	الدمام، حي الخليج، طريق الملك سعود، 32425
رقم السجل التجاري / الرخصة / العقد / الهوية	7051824584
المدة الضريبية	ربع سنوي - Quarterly
تاريخ استحقاق أول إقرار ضريبي	2026/01/31

ملاحظة: ممتلكين مسجلين في ضريبة القيمة المضافة، لا يجوز لكم تحصيل ضريبة القيمة المضافة من عملائكم قبل تاريخ نفاذ التسجيل في الضريبة. و في حال تبين غير ذلك ستلزم هيئة الزكاة والضريبة و الجمارك بتلقيح الغرامات المستحقة التسجيل في الضريبة. و في حال تبين غير ذلك ستلزم هيئة الزكاة والضريبة و الجمارك بتلقيح الغرامات المستحقة التسجيل في الضريبة. و في حال تبين غير ذلك ستلزم هيئة الزكاة والضريبة و الجمارك بتلقيح الغرامات المستحقة التسجيل في الضريبة.

Note: As a VAT registered taxpayer, you are not allowed to collect VAT from your customers prior to the effective date of the tax registration. If otherwise approved, The ZAKAT, Tax and Customs Authority will impose the applicable penalties

شركة نماء التكاملية
NAMAA INTEGRATED CO. LTD.

إثبات عنوان
Address Proof

العنوان الوطني
NATIONAL ADDRESS

رقم الإثبات: 1074998132
تاريخ الإصدار: 11/11/2025
تاريخ الانتهاء: 10/5/2026

بيانات صاحب العنوان
Address Holder Details

الاسم: شركة نماء التكاملية
Name: nama atakamuliah Company

رقم الحساب: 3 1 3 3 3 5 3 1 5 1 7
Customer Acc.

تاريخ التسجيل: 11/11/2025
Reg. Date

تفاصيل العنوان
Address Details

العنوان المختصر: E M D A 4 7 8 3
Short Address

رقم المبنى: 4 7 8 3
Building No.

الشارع: طريق الملك سعود
Street: King Saud Rd

الرقم القرعي: 6 2 4 8
Secondary No.

الحي: حي الخليج
District: Al Khalij Dist.

الرمز البريدي: 3 2 4 2 5
Postal Code

المدينة: 3 2 4 2 5
City

